KIT PART NUMBER 7800043
INSTRUCTIONS FOR RETROFITTING CAHSCODE RECYCLER IN
EXISTING MODEL 780 REFRESHMENT CENTER MACHINE.

CHECK THE PARTS RECEIVED IN THE KIT WITH THE PARTS LIST IN THESE INSTRUCTIONS. IF ANY PARTS ARE MISSING, CONTACT THE NV PARTS DEPARTMENT IMMEDIATELY AT 1-800-621-7278.

Read these instructions carefully before installing the kit.
Keep these instructions for part numbers and for future reference.

THIS KIT CONTAINS THE FOLLOWING :

PART NUMBER	DESCRIPTION	QUANTITY
5900453	CASHCODE VALIDATOR/RECYCLER	1
7805018	HOUSING-PCB	1
7805019	COVER-HOUSING PCB	1

1. **WARNING! Electrical Shock Hazard - Turn machine off before installing this kit. Failure to do so could result in electrical shock.**
2. Read these instructions carefully before installing this kit.
3. Turn the machine OFF with the main switch. Failure to do so could result in an electrical shock.
4. The PCB housing must be moved and a thinner PCB housing installed to make room for the recycler.
5. Remove the PCB Housing cover and screws. **DO NOT DISCARD THE SCREWS.**
6. Disconnect the harnessing from the control PCB, being very careful to note the location of the harness connections.
7. Remove the control PCB and the PCB standoffs from the housing and set aside in a static safe area. **DO NOT DISCARD THE SCREWS OR STANDOFFS.**
8. Remove the PCB Housing. **DO NOT DISCARD THE SCREWS.**
9. Drill 2 x 1/8" holes 3/8" forward of the PCB housing screw holds on the vertical flange of the monetary weld panel.
10. Drill 1 x 3/16" hole 3/8" forward of the PCB housing screw hole on the horizontal flange of the monetary weld panel.

-
11. Cut the back part of the metal out of the monetary weld panel flange so that the PCB standoffs will clear the monetary panel. (See Drawing)
 12. Install the new PCB housing, and reinstall the control PCB and harnessing in the reverse order that they were removed.
 13. Install the CashCode Recycler/Validator using the special 9900222 Barrel Nuts provided in the CashCode packaging.
 14. Re-install the harnessing from the existing bill validator to the CashCode Recycler/Validator.
 15. Turn machine on with the main switch.

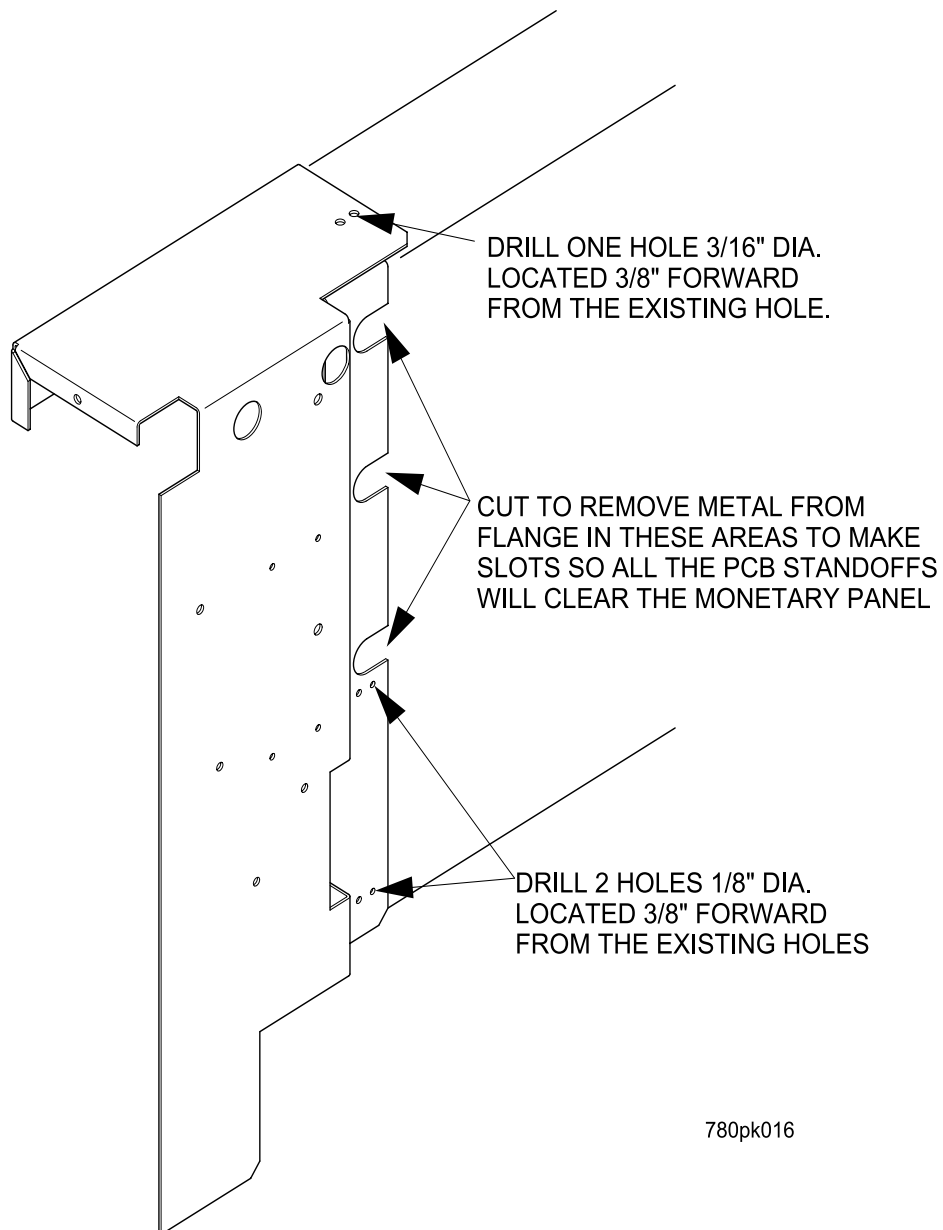

780pk016